

1. A box is pulled along the floor using two identical ropes. The tensions in the ropes act in the directions shown and have magnitudes T_P and T_Q . The box moves at a constant speed in the direction shown.

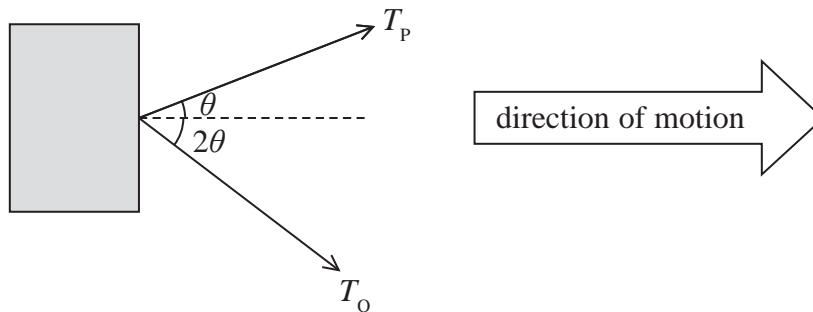

The magnitude of the frictional force acting on the box is equal to

- A $T_P \sin \theta + T_Q \sin 2\theta$
- B $T_P \cos \theta + T_Q \cos 2\theta$
- C $T_P + T_Q$
- D zero

(Total for Question 9 = 1 mark)

2 A potential difference of 600 mV is applied across a circuit component.
What is the energy transferred when a charge of 2 C flows through the component?

- A 1200 J
- B 300 J
- C 1.33 J
- D 1.2 J

(Total for Question = 1 mark)

- 3 The diagram represents a resistor of resistance R in a series circuit with a cell of e.m.f. ε and internal resistance r .

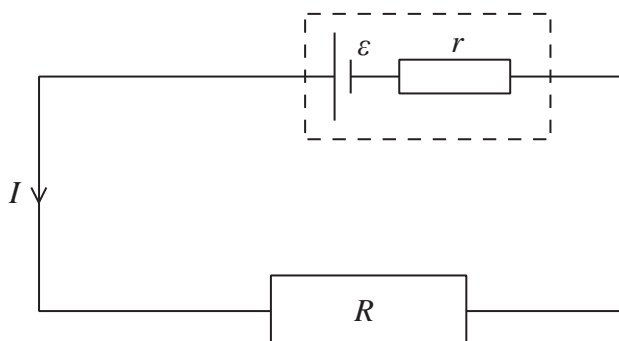

Which of the following correctly gives the potential difference V across the internal resistance?

- A** $V = \frac{\varepsilon(R + r)}{r}$
- B** $V = \frac{\varepsilon R}{R + r}$
- C** $V = \frac{\varepsilon(R + r)}{R}$
- D** $V = \frac{\varepsilon r}{(R + r)}$

(Total for Question = 1 mark)

- 4 A combination of resistors is connected to a 12 V supply of negligible internal resistance.

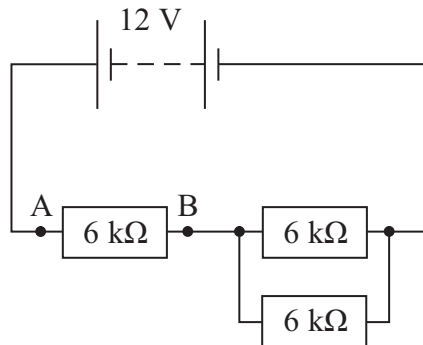

The potential difference between points A and B is

- A 4 V
- B 6 V
- C 8 V
- D 12 V

(Total for Question 1 mark)

- 5 The diagram shows a resistor of resistance R across a cell of e.m.f. ε and internal resistance r .

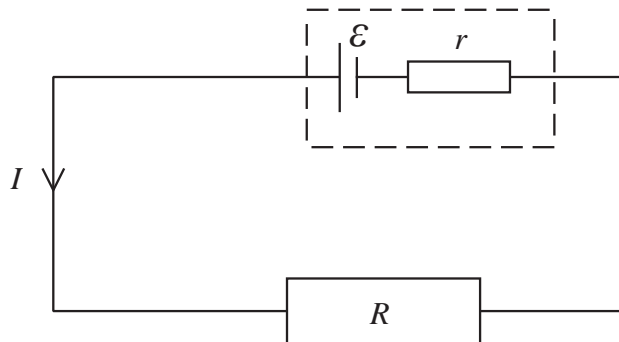

Which of the following is a correct expression for the current I ?

- A $I = \varepsilon / r$
- B $I = \varepsilon / R$
- C $I = \varepsilon / (R + r)$
- D $I = \varepsilon / (R - r)$

(Total for Question = 1 mark)

- 6 Which of the following expresses the volt in SI base units?

- A $\text{kg m}^2 \text{s}^{-2} \text{C}^{-1}$
- B $\text{kg m}^2 \text{s}^{-3} \text{C}$
- C $\text{kg m}^2 \text{s A}^{-1}$
- D $\text{kg m}^2 \text{s}^{-3} \text{A}^{-1}$

(Total for Question 1 mark)